

# Clinical Outcomes of BRYAN Cervical Disc Arthroplasty: A Prospective, Randomized, Controlled, Multicenter Trial With 24-month Follow-up

Rick C. Sasso, MD,\* Joseph D. Smucker, MD,† Robert J. Hacker, MD,‡ and John G. Heller, MD§

**Study Design/Setting:** Prospective, randomized, 3-center, clinical trial.

**Objective:** To prospectively compare the outcomes of cervical arthroplasty with the BRYAN Cervical Disc Prosthesis (Medtronic Sofamor Danek, Inc, Memphis, TN) to anterior cervical discectomy and fusion (ACDF).

**Summary of Background Data:** Surgical treatment of cervical disc pathology commonly involves techniques that employ discectomy and fusion (ACDF). This “gold-standard” technique has demonstrated good clinical and radiographic outcomes. Common adverse effects of this procedure are associated with the adjacent level degeneration and bone-graft harvest. Several investigators have independently reported successful short-term outcomes with the BRYAN Cervical Disc Prosthesis. In addition, a significant body of knowledge has been collected regarding the wear patterns and adjacent level effects of this device in human and animal models.

**Methods:** As part of an FDA IDE trial, 3 centers collected prospective outcomes data on 115 patients randomized in a 1:1 ratio to ACDF (Control group) or arthroplasty with the BRYAN Cervical Disc Prosthesis (Investigational group).

**Results:** Demographic and surgical data were generally similar in the 2 populations. Outcomes data collected at routine postoperative intervals for 24 months demonstrated that the Investigational group had statistically significant ( $P < 0.05$ ) improvements as assessed by the Neck Disability Index, the Neck Pain Score, and SF-36 Physical component scores. The improvement in the Mental Component Subscore values for the BRYAN and control groups was equivalent at 24 months ( $P = 0.055$ ). Arm pain relief was similar in both groups ( $P = 0.152$ ). During the course of the 2-year follow-up, 4 patients in the Control group required surgical intervention

and 3 patients in the Investigational group required ACDF for adjacent level disease.

**Conclusions:** At 24 months, cervical arthroplasty with the BRYAN Cervical Disc Prosthesis compares favorably with ACDF as defined by standard outcomes scores.

**Key Words:** Bryan Cervical Disc, cervical arthroplasty, randomized, prospective, cervical fusion, outcomes

(*J Spinal Disord Tech* 2007;20:481–491)

The cervical discs function in load bearing and motion transfer. Much is known about the macro-biology of the intervertebral disc. Disc degeneration and the subsequent manifestations that ensue in the cervical spine are also well documented. For many years, the surgical treatment for pathology in the cervical intervertebral disc has been limited to procedures that remove pathologic disc material and address the bony and neurologic pathology in the region of the excised disc. Anterior cervical discectomy and fusion (ACDF) is a proven intervention for patients with radiculopathy and myelopathy.<sup>1</sup> Because of the limitations specific to this procedure, investigators have developed alternatives to fusion that attempt to address the kinematic and biomechanical issues inherent to fusions.<sup>2–7</sup>

Reoperation rates for adjacent segment degeneration have been documented at a rate of 2.9% of patients per annum, and 25.6% of patients undergoing cervical fusion will have surgery for recurrent symptoms within 10 years of the index fusion.<sup>8</sup> Other reports have helped to shed light on the recurrence of neurologic symptoms and degenerative changes adjacent to fused cervical levels.<sup>9,10</sup> Segments adjacent to a fusion have an increased range of motion and increased intradiscal pressures.<sup>11,12</sup>

Pseudarthrosis is another complication encountered with anterior cervical fusion procedures. There is a relationship between the rate of pseudarthrosis and the number of levels fused. Brodke and Zdeblick<sup>13</sup> reported a 97% fusion rate in single-level ACDF, which decreased to 83% with fusion at 3 levels. Bohlman et al<sup>1</sup> reported an 11% pseudarthrosis rate in single-level fusions that increased to 27% with multilevel fusions.

Complications associated with autologous iliac crest harvest, traditionally used as a fusion graft in ACDF, are

Received for publication April 26, 2006; accepted December 3, 2006.

From the \*Indiana Spine Group, Clinical Orthopaedic Surgery, Indiana University School of Medicine, Indianapolis, IA; †Department of Orthopaedic Surgery, The University of Iowa, Iowa City, IA; ‡Oregon Neurosurgery Specialists, Eugene, OR; and §Emory Spine Center, Department of Orthopaedic Surgery, Emory University, Atlanta, GA.

Reprints: Joseph D. Smucker, MD, Department of Orthopaedics, The University of Iowa, 200 Hawkins Drive, 01017 JPP, Iowa City, IA 52242 (e-mail: joe@smuckermd.com).

Copyright © 2007 by Lippincott Williams & Wilkins

also well documented. Sandhu et al<sup>14</sup> reported a complication rate of 1% to 25% with such procedures. Complications such as acute and chronic pain, infection, neuralgia paresthetica, and pelvic fracture are known to occur at harvest donor sites.<sup>15,16</sup>

Total intervertebral disc replacement (TDR) is designed to preserve motion, avoid limitations of fusion, and allow patients to quickly return to routine activities. The primary goals of the procedure in the cervical spine are to restore disc height and preserve segmental motion after removing the source of nerve root or spinal cord compression. A secondary intention is the preservation of normal motion at adjacent cervical levels, which may be theorized to retard later adjacent level degeneration. It avoids the morbidity of bone-graft harvest.<sup>17,18</sup> It also avoids complications such as pseudarthrosis, issues attributed to anterior cervical plating, and cervical immobilization side effects.

The BRYAN Cervical Disc Prosthesis (Medtronic Sofamor Danek, Inc, Memphis, TN) is a 1-piece, biarticulating, metal-on-polymer, unconstrained device with a fully variable instantaneous axis of rotation that is not dependent on supplemental fixation<sup>2,3</sup> (Figs. 1, 2). It has a polyurethane sheath that is designed to contain wear debris and prevent soft tissue ingrowth. Each endplate is porous coated to promote bony ingrowth for long-term device stability. Although initial clinical use commenced in Europe during January 2006, the BRYAN cervical disc replacement became the first such device to initiate a clinical trial in the United States in May 2002. The purpose of this paper is to report a subset of data from 3 of the clinical investigative centers for the FDA IDE trial.

## MATERIALS AND METHODS

### Patients

One hundred and fifteen patients were enrolled and followed prospectively at 3 centers involved in a multicenter, FDA IDE trial for the BRYAN Cervical Disc Prosthesis. Patients with single-level, symptomatic, cervical radiculopathy or myelopathy refractory to nonoperative interventions were randomized in a 1:1 ratio to a single-level ACDF with allograft and plate (Control

group) or single-level cervical arthroplasty with the BRYAN Cervical Disc Prosthesis (Investigational group). Preoperative imaging studies included plain radiographs, magnetic resonance imaging, and computed tomography. The latter was helpful in excluding significant spondylosis and facet joint arthrosis.

### Surgery

The surgical technique was similar in both groups to the point of interbody fusion/arthroplasty. A standard Smith-Robinson approach was made to expose the symptomatic level. After appropriate exposure and localization of the disc, a discectomy was performed. After discectomy, a local decompression was accomplished via foraminotomies and resection of osteophytes and/or the posterior longitudinal ligament at the treating surgeon's discretion.

Endplate preparation for ACDF was completed with a high-speed burr and an appropriately sized Cornerstone SR fibular allograft (Medtronic Sofamor Danek, Inc, Memphis, TN) was placed in the prepared interspace. All ACDF patients underwent anterior cervical plating with the Atlantis Vision Cervical Plate System (Medtronic Sofamor Danek, Inc, Memphis, TN).

Preparation of the endplates for arthroplasty was accomplished in the standard technique. The BRYAN disc milling technique creates 2 concave surfaces via a milling jig. Sizing of the BRYAN cervical disc was determined with a combination of templates and preoperative radiographic studies including computed tomography.<sup>19</sup> The center of the disc space was determined intraoperatively by a jig that defines the uncovertebral joints and finds the center. With knowledge of the center of the disc space, a milling fixture was anchored to the vertebral bodies. This fixture controlled the cutting tools which mill the endplates to the exact geometry of the device endplates providing immediate stability (Fig. 3).<sup>19</sup>

Insertion of the TDR was accomplished under lateral fluoroscopy to assure adequate depth. Before inserting the BRYAN disc, the implant was filled with saline as an initial lubricant.<sup>19</sup> The prosthesis was then placed into the milled interspace (Fig. 3). Before closure of the incision, appropriate placement of the TDR was



**FIGURE 1.** The BRYAN Cervical Disc Prosthesis (© Courtesy of Medtronic Sofamor Danek, Memphis, TN; with permission).<sup>31</sup>

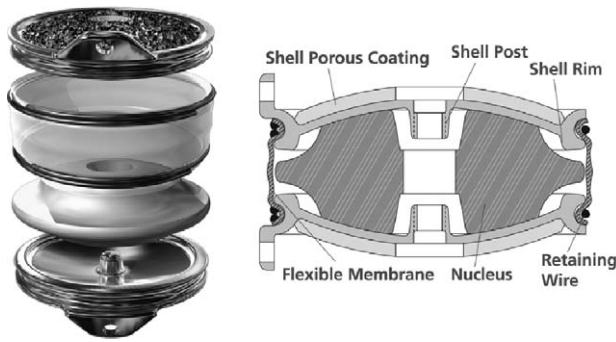

**FIGURE 2.** The BRYAN Cervical Disc Prosthesis Design (© Courtesy of Medtronic Sofamor Danek, Memphis, TN; with permission).<sup>31</sup>

confirmed with anteroposterior and lateral fluoroscopic imaging.

**Data Collection**

Preoperative demographic data, surgical data, and outcomes data were collected on all patients. Clinical outcome tools included: Neck Disability Index (NDI), Arm Pain Score (VAS), Neck Pain Score (VAS), and SF-36. Outcome assessments were made preoperatively and at 6 weeks, 3 months, 6 months, 12 months, and 24 months. Collected data were statistically analyzed and tabulated (Tables 1, 2).

Radiographic angular motion at the target level was tracked on digital radiographs using quantitative motion analysis software (QMA, Medical Metrics, Houston, TX) to calculate the functional spine unit motion parameters by 2 blinded, trained observers. The recorded values of angulation at the treated levels are the absolute value of extension minus flexion from the 2 readers' measurements. These values were tabulated and statistically analyzed as presented in Tables 7A and 7B.

**Statistical Analysis**

Statistical analysis was performed using SAS (SAS Institute Inc, Cary, NC). For continuous variables, statistical analysis and *P* values were calculated by

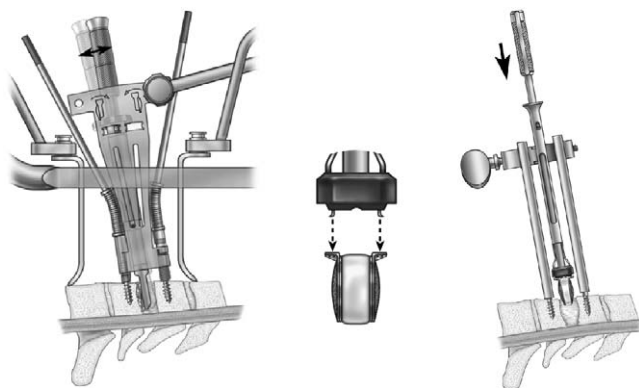

**FIGURE 3.** Endplate preparation and BRYAN TDR implant insertion (© Courtesy of Medtronic Sofamor Danek, Memphis, TN; with permission).<sup>19</sup>

**TABLE 1.** Demographic Information

Variable	Investigational (N = 56)	Control (N = 59)	<i>P</i> *
Age (y)			
Mean ± SD	42.5 ± 7.8	46.1 ± 7.8	0.015
Height (in)			
Mean ± SD	67.9 ± 3.5	67.7 ± 3.7	0.728
Weight (lbs)			
Mean ± SD	173.6 ± 42.6	180.8 ± 39.2	0.343
Sex [N (%)]			
Male	30 (53.6)	32 (54.2)	1.000
Female	26 (46.4)	27 (45.8)	
Race [N (%)]			
White	53 (94.6)	56 (94.9)	0.469
Black	0 (0.0)	0 (0.0)	
Asian	0 (0.0)	1 (1.7)	
Hispanic	1 (1.8)	2 (3.4)	
Other	2 (3.6)	0 (0.0)	
Marital status [N (%)]			
Single	4 (7.1)	5 (8.5)	0.968
Married	45 (80.4)	48 (81.4)	
Divorced	6 (10.7)	6 (10.2)	
Separated	1 (1.8)	0 (0.0)	
Widowed	0 (0.0)	0 (0.0)	
Education level [N (%)]			
< High school	6 (10.7)	8 (13.6)	0.562
High school	13 (23.2)	18 (30.5)	
> High school	37 (66.1)	33 (55.9)	
Tobacco used [N (%)]			
Yes	12 (22.2)	10 (16.9)	0.635
No	42 (77.8)	49 (83.1)	
Alcohol used to relieve neck pain [N (%)]			
Yes	2 (3.7)	3 (5.1)	1.000
No	52 (96.3)	56 (94.9)	
Preoperative work status [N (%)]			
Currently working	41 (73.2)	42 (71.2)	0.838
Not working	15 (26.8)	17 (28.8)	

\*For continuous variables, *P* values are from analysis of variance and for categorical variables, they are from Fisher exact test.

analysis of variance and for categorical values a Fisher exact test was employed. A paired *t* test was used to calculate the statistical significance of change from the preoperative score in SF-36, NDI, Neck Pain, and Arm Pain categories. It was also employed for the analysis of motion scores at the target level when change from preoperative angulation was recorded.

**RESULTS**

**Demographic and Surgical Data**

One hundred and fifteen patients were randomized in a 1:1 ratio to either a BRYAN Cervical Disc (N = 56) or an anterior cervical fusion with allograft and a plate (N = 59). There were 30 males and 26 females in the BRYAN group and 32 males and 27 females in the fusion group. The average age was 42 years (BRYAN) and 46 years (Control). No statistically significant differences were noted in the demographics of the Investigational and

**TABLE 2.** Surgical and Discharge Data

Variable	Investigational (N = 56)	Control (N = 59)	P*
Operative time (h)			
Mean ± SD	1.7 ± 0.5	1.1 ± 0.4	< 0.001
Blood loss (mL)			
Mean ± SD	64.6 ± 49.6	49.2 ± 39.6	0.068
Hospital stay (d)			
Mean ± SD	0.9 ± 0.4	0.6 ± 0.6	< 0.001
Treatment levels [N (%)]			
C3-C4	1 (1.8)	0 (0.0)	0.579
C4-C5	2 (3.6)	3 (5.1)	
C5-C6	27 (48.2)	34 (57.6)	
C6-C7	26 (46.4)	22 (37.3)	
External orthosis [N (%)]			
None	34 (60.7)	5 (8.5)	< 0.001
Soft collar	21 (37.5)	49 (83.1)	
Rigid collar	0 (0.0)	4 (6.8)	
Halo	0 (0.0)	0 (0.0)	
Cervical brace	0 (0.0)	0 (0.0)	
Other	1 (1.8)	1 (1.7)	

\*For continuous variables, P values are from analysis of variance and for categorical variables, they are from Fisher exact test.

control populations with the exception of age ( $P = 0.015$ ) (Table 1).

The average operative time for the Control group was 1.1 hours and the BRYAN group 1.7 hours ( $P < 0.001$ ). Average blood loss was similar. Average hospital stay was 0.5 days (Control) and 1 day (BRYAN) ( $P < 0.001$ ). Additional surgical data are reported in Table 2.

**Outcomes Data**

The changes in the mean SF-36 Physical Component Subscores (PCS) were notable (Table 3A, Fig. 4). The mean preoperative score for the BRYAN group was 34, whereas it was 32 for the Control group ( $P = 0.111$ ). The 12-month follow-up PCS data were available for 109 patients (55 BRYAN and 54 Control). At this interval, the mean PCS had increased to 51 for the BRYAN group and 47 for the Control ( $P = 0.036$ ). At 24 months postoperatively, the mean PCS for the BRYAN group was 50, whereas the Control group mean was 45 ( $P = 0.016$ ). At that same time point, the PCS change from the preoperative score (Table 3B) was significant in both the Investigational and Control groups ( $P < 0.001$ ).

The mean preoperative SF-36 Mental Component Subscore (MCS) was 46 and 49 for the BRYAN and Control groups, respectively ( $P = 0.193$ ). By 24 months after the surgery, the mean MCS values were 55 for the BRYAN group and 50 for the Control group ( $P = 0.055$ ) (Table 3A). At that same time point, the MCS change from the preoperative score (Table 3B) was significant in the Investigational group ( $P = 0.005$ ) and insignificant in the Control groups ( $P = 0.565$ ).

The mean preoperative NDI scores were 47 and 49 for the BRYAN and Control groups, respectively

**TABLE 3A.** Summary of SF-36 Health Survey Scores

Period	Variable	Investigational	Control	P*
Preoperative	PCS			
	N	56	59	
	Mean ± SD	34.2 ± 7.3	32.0 ± 7.1	0.111
6 wk	MCS			
	N	56	59	
	Mean ± SD	46.3 ± 12.4	49.0 ± 9.5	0.193
3 mo	PCS			
	N	55	58	
	Mean ± SD	42.8 ± 9.0	38.9 ± 8.9	0.025
6 mo	MCS			
	N	55	58	
	Mean ± SD	53.2 ± 8.6	49.8 ± 9.5	0.051
12 mo	PCS			
	N	54	57	
	Mean ± SD	48.3 ± 8.2	45.8 ± 9.5	0.133
24 mo	MCS			
	N	54	57	
	Mean ± SD	53.7 ± 7.9	49.9 ± 10.4	0.037
Preoperative	PCS			
	N	49	54	
	Mean ± SD	49.0 ± 9.6	45.3 ± 11.2	0.079
6 wk	MCS			
	N	49	54	
	Mean ± SD	55.3 ± 6.1	51.2 ± 10.8	0.020
3 mo	PCS			
	N	55	54	
	Mean ± SD	50.8 ± 9.3	46.7 ± 10.7	0.036
6 mo	MCS			
	N	55	54	
	Mean ± SD	54.4 ± 8.4	52.6 ± 9.0	0.282
12 mo	PCS			
	N	36	35	
	Mean ± SD	50.5 ± 9.6	44.6 ± 10.6	0.016
24 mo	MCS			
	N	36	35	
	Mean ± SD	54.6 ± 7.7	50.5 ± 10.1	0.055

\*P values for change from preoperative in each group are from paired t test.

**TABLE 3B.** SF-36 Health Survey Scores—24 mo Change

Period	Variable	Investigational	Control
Preoperative	PCS		
	N	56	59
	Mean ± SD	34.2 ± 7.3	32 ± 7.1
24 mo	MCS		
	N	56	59
	Mean ± SD	46.3 ± 12.4	49 ± 9.5
Preoperative	PCS change from preoperative		
	N	36	35
	Mean ± SD	15.8 ± 9.5	12.4 ± 11.0
	P*	< 0.001	< 0.001
Preoperative	MCS change from preoperative		
	N	36	35
	Mean ± SD	5.8 ± 11.6	1.1 ± 11.0
	P*	0.005	0.565

\*P values for change from preoperative in each group are from paired t test.

( $P = 0.454$ ) (Table 4A). Twelve-month follow-up data were available for 109 patients (55 BRYAN and 54 Control) with the mean NDI scores falling to 10 in the

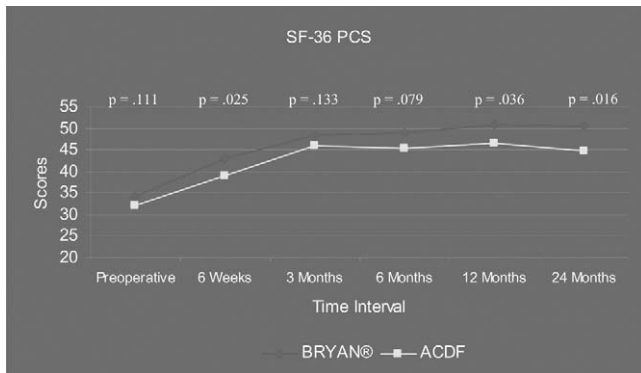

FIGURE 4. SF-36 PCS Scores—a graphical representation.<sup>32</sup>

BRYAN group and 18 among the Control patients. The degree of improvement was significantly greater in the BRYAN cohort at this time point ( $P = 0.012$ ). Two-year follow-up data were available for 71 patients (36 BRYAN and 35 Control). At this interval, the mean NDI for scores the BRYAN and Control groups were 12 and 23, respectively ( $P = 0.006$ ). At the 2-year interval, the NDI change from the preoperative score (Table 4B) was significant in both the Investigational and Control groups ( $P < 0.001$ ).

The mean neck pain VAS values preoperatively were 72 and 73 for the BRYAN and Control groups, respectively ( $P = 0.845$ ) (Table 5A, Fig. 5). Twelve-month follow-up data were available for 109 patients (55 BRYAN and 54 Controls) with the mean VAS values improving to 17 in the BRYAN group and to 27 in the

Control patients. The degree of neck pain improvement at this time point was equivalent between the 2 groups ( $P = 0.056$ ). For the 71 patients reaching 2-year follow-up (36 BRYAN and 35 Control), the mean VAS for the BRYAN group was 19 and for the Control group 36. By this time point, the neck pain improvement seemed to be significantly better for the BRYAN patients ( $P = 0.014$ ) (Fig. 5). In addition to the group-to-group differences noted, both groups demonstrated a significant improvement in comparison with their preoperative scores ( $P < 0.001$ ) (Table 5B).

The mean arm pain VAS values (Table 6A) preoperatively were 70 (BRYAN) and 71 (Control). At 12 months, follow-up data were available for 109 patients (55 BRYAN and 54 Controls) with the mean BRYAN arm pain VAS values improving to 12 and mean Control values improving to 22 ( $P = 0.037$ ). For the 71 patients reaching 2-year follow-up, the mean arm pain VAS for the BRYAN group was 17, whereas it was 27 for the Control group ( $P = 0.152$ ). Although no group-to-group differences were noted at 24 months, both groups demonstrated a significant improvement in comparison with their preoperative scores ( $P < 0.001$ ) (Table 6B).

### Target-level Motion Analysis

Cervical vertebral bodies were tracked on the digital radiographs using quantitative motion analysis software (QMA, Medical Metrics, Houston, TX) to calculate the functional spine unit motion parameters. As expected, significantly more motion (3, 6, 12, and 24mo) was retained in the disc replacement group than the plated group at the index level. The disc replacement group

TABLE 4A. NDI Scores

Period	Variable	Investigational (N = 56)	Control (N = 59)	P
Preoperative Pain Score	N	56	59	
	Mean ± SD	46.5 ± 17.2	48.7 ± 15.1	0.454
6 wk Pain Score	N	55	58	
	Mean ± SD	19.5 ± 16.3	29.0 ± 17.4	0.003
3 mo Pain Score	N	54	57	
	Mean ± SD	13.4 ± 13.5	22.8 ± 20.0	0.005
6 mo Pain Score	N	49	54	
	Mean ± SD	11.8 ± 13.4	20.5 ± 19.5	0.010
12 mo Pain Score	N	55	54	
	Mean ± SD	9.9 ± 12.9	17.8 ± 19.0	0.012
24 mo Pain Score	N	36	35	
	Mean ± SD	11.6 ± 15.6	23.1 ± 18.6	0.006

TABLE 4B. NDI Scores—24 mo Change

Period	Variable	Investigational (N = 56)	Control (N = 59)
Neck Disability Index Scores	Preoperative Pain Score		
	N	56	59
24 mo Pain Score	Mean ± SD	46.5 ± 17.2	48.7 ± 15.1
	Change from preoperative		
	N	36	35
	Mean ± SD	-28.9 ± 15.0	-23.7 ± 19.9
	P*	< 0.001	< 0.001

\*P values for change from preoperative in each group are from paired t test.

**TABLE 5A.** Neck Pain Scores

Period	Variable	Investigational	Control	P
Preoperative Pain Score	N	56	58	
	Mean ± SD	72.0 ± 24.7	72.8 ± 24.0	0.847
6 wk Pain Score	N	55	58	
	Mean ± SD	28.5 ± 24.1	35.7 ± 26.3	0.131
3 mo Pain Score	N	54	57	
	Mean ± SD	23.6 ± 22.7	34.9 ± 29.5	0.026
6 mo Pain Score	N	49	54	
	Mean ± SD	22.2 ± 23.0	32.7 ± 30.1	0.052
12 mo Pain Score	N	55	54	
	Mean ± SD	17.2 ± 22.4	27.0 ± 30.4	0.056
24 mo Pain Score	N	36	35	
	Mean ± SD	18.5 ± 26.2	35.6 ± 30.6	0.014

**TABLE 5B.** Neck Pain Scores—24 mo Change

Period	Variable	Investigational	Control
Preoperative Pain Score	N	56	58
	Mean ± SD	72.0 ± 24.7	72.8 ± 24.0
24 mo Pain Score	Change from preoperative		
	N	36	35
	Mean ± SD	-48.2 ± 30.5	-36.4 ± 31.1
	P*	< 0.001	< 0.001

\*P values for change from preoperative in each group are from paired *t* test.

retained an average of 7.3 degrees at 12 months and 7.0 degrees at 24 months (Table 7A). In the 24-month BRYAN group, this did not represent a statistically significant change from the preoperative measured angulation at the target level ( $P = 0.104$ ). In contrast, the average range of motion in the fusion group was 1.3 degrees at the 3-month follow-up and gradually decreased to 0.9 degrees at 24 months, a significant change from the preoperative measurements ( $P < 0.001$ ) (Table 7B).

## Complications

Over the 24-month follow-up period, a total of 7 subsequent surgical interventions were performed in the study population (4 Control, 3 Investigational). All subsequent surgical interventions were performed by the initial treating surgeon at the discretion of that surgeon

(Table 8). One patient in the Control group (JA17, Table 8) required a posterior cervical fusion for symptomatic nonunion. Another patient in the Control group (LA07, Table 8) required revision ACDF for nonunion, which was performed with allograft and *rh*BMP-2 (INFUSE, Medtronic Sofamor Danek, Memphis, TN) and revision anterior cervical plating. This same patient later required posterior fusion with autograft for a recurrent nonunion. Two patients in the Control group required ACDF for adjacent level disease during the 24-month period (VA11 and VA20, Table 8).

Three patients in the Investigational group required ACDF for adjacent level disease during the 24-month follow-up period (VA 25, 35, and 59, Table 8). There were no incidents of radiographic or clinical implant complications noted at the target surgical levels (BRYAN disc replacement) in the Investigational group. No spontaneous fusion or heterotopic ossification (HO) events were observed in the Investigational group.

## DISCUSSION

At the time of this writing, multiple cervical disc arthroplasty devices are involved in US IDE trials. No device has yet obtained FDA approval. This 24-month, 3-site series represents a subset of the 31 institutions involved in the FDA IDE trial for the BRYAN cervical disc replacement. As expected, the 1:1 randomization process yielded demographically similar study groups. The surgical data were similar in many respects with a trend toward longer hospital stay and longer operative time in the Investigational BRYAN group. Our study demonstrates significant improvement (Investigational

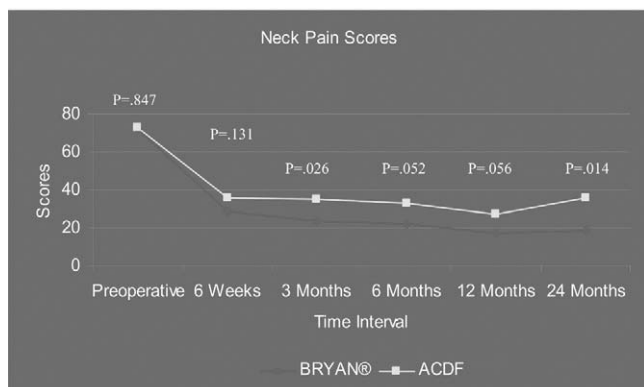

**FIGURE 5.** Neck Pain Scores—a graphical representation.<sup>32</sup>

**TABLE 6A.** Arm Pain Scores

Period	Variable	Investigational	Control	P
Preoperative Pain Score	N	56	59	0.832
	Mean ± SD	69.8 ± 19.0	70.7 ± 23.7	
6 wk Pain Score	N	55	58	0.078
	Mean ± SD	15.5 ± 22.2	23.5 ± 25.9	
3 mo Pain Score	N	54	57	0.234
	Mean ± SD	15.8 ± 23.0	22.0 ± 30.7	
6 mo Pain Score	N	49	54	0.116
	Mean ± SD	15.6 ± 24.4	24.0 ± 28.8	
12 mo Pain Score	N	55	54	0.037
	Mean ± SD	11.9 ± 19.6	22.2 ± 30.2	
24 mo Pain Score	N	36	35	0.152
	Mean ± SD	16.8 ± 28.2	26.9 ± 30.3	

**TABLE 6B.** Arm Pain Scores—24 mo Change

Period	Variable	Investigational	Control
Preoperative Pain Score	N	56	59
	Mean ± SD	69.8 ± 19.0	70.7 ± 23.7
24 mo Pain Score	Change from preoperative		
	N	36	35
	Mean ± SD	-48.9 ± 27.2	-42.9 ± 37.0
	P*	< 0.001	< 0.001

\*P values for change from preoperative in each group are from paired t test.

group vs. Control group) in multiple outcome measures at 12 and 24 months including: SF-36 PCS, NDI, and neck pain VAS. Although both surgical groups had statistically significant improvement in all outcome measures at 24 months with respect to their preoperative scores, the outcome-based group-to-group comparison at the follow-up intervals is highly suggestive of the benefit of the Investigational implant in the 24-month period examined by this study.

Our results with regard to surgical outcomes are similar to those of other investigators and represent the largest single randomized, controlled, prospective series of patients with BRYAN Disc arthroplasty followed to 24 months. Goffin et al<sup>3</sup> reported early results of a multicenter study of the BRYAN Disc performed at a single disc space in 60 patients for the treatment of radiculopathy or myelopathy owing to disc herniation or spondylosis failing at least 6 weeks of conservative treatment. Exclusion criteria included previous cervical spine surgery, axial neck pain as the sole symptom, significant anatomic deformity, and radiographic evidence of instability (translation > 2 mm or > 11 degrees of angulation compared with the adjacent level). Patient outcomes were determined by the Cervical Spine Research Society and SF-36 instruments. Clinical success rates at 6 months and 1 year were 86% and 90%, respectively, exceeding the study's targeted success rate of 85%. Unfortunately, the study's findings have been subject to some skepticism, because there was no Control group.

In a separate report, Goffin et al<sup>4</sup> have recently published the intermediate-term results of this multicenter

study. The study was expanded to include a second arm evaluating the treatment of 2 adjacent disc levels. The single-level arm had 103 patients enrolled with 100 reaching the 1-year mark and 51 reaching 2-year follow-up. The bilevel study arm was comprised of 43 patients with 1-year data completed on 29 patients and 2-year data available on 1 patient. Success rates in the single-level study at 6 months, 12 months, and 24 months were 90%, 86%, and 90% respectively. In the bilevel study, the success rate at 6 months was 82% and 96% at 1 year. No device failures or subsidence were observed in any patient. At 1-year follow-up, flexion-extension range of motion per level averaged 7.9 degrees in the single-level arm and 7.4 degrees in the bilevel arm.

Anderson et al<sup>2</sup> described the follow-up results of 73 patients who had greater than 2-year follow-up status on a 1-level BRYAN Disc Arthroplasty. Forty-five of these patients were rated as excellent, 7 as a good, and 13 as fair. Only 8 patients had a poor rating at the 2-year follow-up. SF-36 functional outcome data demonstrated significant improvement from preoperative to 3-month postoperative time points. These outcomes remained stable 24 months after the surgery. There was no radiographic evidence of subsidence of implants. Eighty-nine percent of all patients had at least 2 degrees of motion at 1 and 2 years. Average range of motion was 8 degrees. There was one early anterior device migration associated with a partially milled cavity.

This same report noted the results of 30 patients who had 2 level disc arthroplasty and had reached the 1-year end point in follow-up. Twenty-one of the patients were rated as excellent, 3 good, 5 fair, and 1 poor.

**TABLE 7A.** Summary of Angular Motion at Treated\* Levels

Period	Variable	Investigational			Control		
		Reader 1	Reader 2	Average†	Reader 1	Reader 2	Average†
Preoperative	Angulation at the target level						
	N	140	174	136	122	155	120
	Mean ± SD	6.30 ± 3.99	6.39 ± 3.69	6.51 ± 3.37	7.06 ± 4.28	9.21 ± 5.18	8.15 ± 4.43
3 mo	Angulation at the target level						
	N	175	169	168	76	77	72
	Mean ± SD	5.26 ± 3.00	6.78 ± 3.62	5.97 ± 3.13	1.49 ± 1.44	1.06 ± 1.04	1.26 ± 0.99
6 mo	Angulation at the target level						
	N	174	166	165	78	82	73
	Mean ± SD	6.34 ± 3.87	7.89 ± 4.21	7.12 ± 3.83	1.80 ± 3.25	1.09 ± 1.31	1.37 ± 1.72
12 mo	Angulation at the target level						
	N	138	137	136	80	68	63
	Mean ± SD	6.29 ± 4.10	8.21 ± 4.77	7.27 ± 4.28	1.19 ± 1.34	0.77 ± 0.99	0.94 ± 0.81
24 mo	Angulation at the target level						
	N	68	58	57	44	38	33
	Mean ± SD	6.01 ± 4.30	7.88 ± 4.43	7.04 ± 4.29	1.12 ± 1.34	0.79 ± 0.73	0.85 ± 0.71

\*The values of angulations at treated levels are the absolute value of (EXT-FLEX) from the 2 readers' measurements.  
 †If the value of 1 of 2 readers' is missing, then the average is treated as missing.

**TABLE 7B.** Summary of Angular Motion at Treated\* Levels—24 mo Change

Period	Variable	Investigational			Control		
		Reader 1	Reader 2	Average†	Reader 1	Reader 2	Average†
Preoperative	Angulation at the target level‡						
	N	140	174	136	122	155	120
	Mean ± SD	6.30 ± 3.99	6.39 ± 3.69	6.51 ± 3.37	7.06 ± 4.28	9.21 ± 5.18	8.15 ± 4.43
24 mo	Change from preoperative for angulation at the target level‡						
	N	47	52	41	39	34	28
	Mean ± SD	0.87 ± 6.39	2.07 ± 4.61	1.40 ± 5.39	-5.64 ± 4.18	-8.42 ± 5.87	-6.52 ± 4.36
	P*	0.357	0.002	0.104	< 0.001	< 0.001	< 0.001

\*The values of angulations at treated levels are the absolute value of (EXT-FLEX) from the 2 readers' measurements.  
 †If the value of 1 of 2 readers' is missing, then the average is treated as missing.  
 ‡P values for change from preoperative in each group are from paired t test.

A significant improvement in SF-36 functional outcome measures was noted postoperatively. There was no radiographic evidence of subsidence in the 2-level patients. At 1 year, 84% of patients had at least 2 degrees

of motion at both disc levels. The average amount of motion at each disc level was also 8 degrees. There was one posterior migration of a device, again associated with a partially milled cavity. Complications in the study as a

**TABLE 8.** Complications

Patient	Treatment/Level	Adjacent Level	Supplemental Fixation	Removal
JA17	Control		Posterior cervical fusion at C5-6	
LA07	Control		Posterior cervical fusion after revision ACDF nonunion	Revision ACDF with rhBMP-2 and anterior spinal instrumentation with Atlantis Vision Plate
VA11	Control/C5-6	ACDF at C6-7		
VA20	Control/C4-5	ACDF at C5-6		
VA25	Investigational/C5-6	ACDF at C6-7		
VA35	Investigational/C4-5	ACDF at C5-6		
VA59	Investigational/C5-6	ACDF at C4-5		

JA-Sasso.  
 LA-Rhee/Heller.  
 VA-Hacker.

whole included: 1 cerebrospinal fluid leak, 1 esophageal injury, 4 hematoma evacuations, and 3 revision decompressions.<sup>2</sup>

Sekhon<sup>20</sup> reported early results of 7 patients with cervical spondylotic myelopathy who were treated with anterior decompression and reconstruction with the BRYAN Disc. Follow-up ranged from 1 to 17 months. On average, the Nurick grade improved by 0.72 and Oswestry NDI scores improved by 51.4 points. Improvement in cervical lordosis was noted in 29% of the patients. No complications were reported.

In another small prospective study, Duggal et al<sup>21</sup> reported on 26 patients undergoing single-level or 2-level implantation of the BRYAN artificial cervical disc for the treatment of cervical degenerative disc disease resulting in radiculopathy and/or myelopathy. Patients were evaluated radiographically and via NDI and SF-36 at regular intervals. Segmental sagittal rotation from C2-3 to C6-7 was measured using quantitative motion analysis software. A total of 30 BRYAN discs were placed in 26 patients. Follow-up duration ranged from 1.5 to 27 months, with a mean duration of 12.3 months. A statistically significant improvement in the mean NDI scores was seen between preoperative and late postoperative follow-up evaluations.

Several complications were observed in our investigation: 4 Control, 3 Investigational. In the Investigational group, 3 patients went on to require surgical intervention at adjacent levels for symptomatic pathology refractory to nonoperative means. In the Control group, 2 patients required surgical intervention at adjacent levels, 1 patient required revision ACDF, and then a second procedure (posterior fusion with autograft) for multiple nonunions, and 1 patient required supplemental posterior cervical fusion.

Our complications may be compared with those described in the series reported by Goffin et al.<sup>4</sup> In the single-level study, 3 patients required subsequent surgical intervention. These procedures included the evacuation of a prevertebral hematoma, a posterior foraminotomy for residual compression, and a posterior laminectomy for residual myelopathy. Four subsequent procedures were required in the bilevel study: evacuation of a prevertebral hematoma, evacuation of an epidural hematoma, repair of a pharyngeal/esophageal injury caused by intubation, and an anterior decompression due to residual nerve root compression. Two patients developed dysphonia after second procedures. One patient initially had a device placed at a wrong level and developed temporary dysphonia after a device was placed at the appropriate level. The other patient developed a second symptomatic disc 21 months after the index procedure and developed severe dysphonia from bilateral vocal cord paralysis after a second device was placed from a contralateral approach.

In the intermediate Goffin study,<sup>4</sup> temporary anteroposterior device migration was detected in 1 patient and suspected in another. This migration was felt to be due to inadequate endplate milling early in the study. This issue

was corrected with modification of the instrument system. Migration greater than 3.5 mm, the radiographic threshold of segmental stability, was not observed.

Although it is difficult to draw statistically relevant conclusions from few reoperative complications observed in our series, it is probable that the long-term follow-up of this cohort will yield further data. In the interim, reoperative rates have been reported in other series and are relevant to the discussion.

Anderson and colleagues studied reoperation rates after cervical spine arthroplasty and cervical spine arthrodesis. Their randomized, prospective, controlled study analyzed data from multiple IDE trials including: US PRESTIGE (Medtronic Sofamor Danek, Memphis, TN) and BRYAN IDE trials, European BRYAN (single level), and PRESTIGE trials. Additional arthrodesis data were obtained from the control groups of the AFFINITY (Medtronic Sofamor Danek, Memphis, TN) Cervical cage. A total of 649 arthroplasties and 580 control arthrodesis patients were analyzed.<sup>22</sup>

The follow-up period for the arthroplasty and arthrodesis groups was comparable and ranged from 6 weeks to 28 months. Among the arthroplasty patients, there were 12 (1.8%) reoperations out of 649, with 10 (1.5%) at the same level, and 4 (0.6%) at another level (some patients had a revision at the same level plus another level). In the arthrodesis group, 21 (3.6%) underwent a reoperation. Nine (1.6%) were at the same level and 13 (2.2%) were at a different level. The difference in reoperation rates was just less than significant ( $P = 0.055$ ). Reoperations at the treated level were similar but reoperations at an adjacent level were significantly higher for the arthrodesed patients ( $P = 0.01$ ). Their results suggest that in the short-term (follow-up < 28 mo), reoperations are more common after arthrodesis than arthroplasties of the cervical spine. This was felt to be due to a greater number of reoperations at adjacent levels following arthrodesis.<sup>22</sup>

Several authors have reported spontaneous ossification after cervical disc arthroplasty with the BRYAN device.<sup>23,24</sup> This complication, manifest as either HO or spontaneous fusion, was not observed in our series. Pickett et al<sup>24</sup> observed a 6.2% complication rate per level in a prospective series of 96 arthroplasty devices implanted in 74 patients. Two of the 96 devices were observed to have loss of motion from ossification or fusion. Leung et al<sup>23</sup> reported a 17.8% incidence of such events at 12 months in the series of patients involved in the European Consortium BRYAN Disc Study. Male sex and advanced age were found to be risk factors for development of HO in this study.

One of the primary goals of cervical disc replacement is to reproduce normal kinematics after implantation (Fig. 6). Our investigation noted preservation of angular motion at the target level at 24 months. This statistically significant finding mirrors the findings of other investigators. Duggal et al<sup>21</sup> have demonstrated preservation of motion in BRYAN-treated spinal segments (mean range of motion 7.8 degrees for up to 24 mo

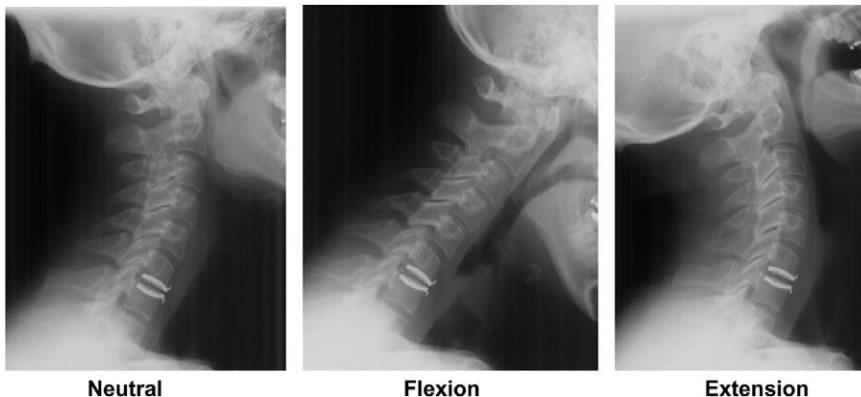

**FIGURE 6.** Postoperative radiographs-kinematics: C6-7 BRYAN disc arthroplasty lateral, flexion, and extension.

postsurgery). The relative contribution of each segment to overall spinal sagittal rotation differed depending on whether the disc was placed at C5-6 or C6-7. Overall cervical motion (C2-7) was moderately increased on late follow-up evaluations.

Patients with symptomatic cervical disc pathology may be treated with a trial of nonoperative management. Indications for surgical intervention include neurologic deficit (refractory to nonoperative treatment or progressive) and refractory radicular pain. Patients with myelopathy secondary to disc herniation are also candidates for discectomy. Cervical TDR in patients with degenerative disease and isolated neck pain has not been adequately examined, is not addressed in this investigation, and is not currently indicated. Exclusion criteria for TDR include: osteoporosis/osteopenia, bone metabolic disease, posterior facet arthropathy, severe myelopathy secondary to bony osteophytes that require resection, chronic infection, tumor, metabolic or systemic disease, and metal allergies.<sup>25</sup> Our investigation demonstrates favorable results with cervical TDR using the BRYAN Disc at 24 months.

### CONCLUSIONS

Although far from being an accepted standard, the concept of artificial cervical disc replacement is gradually becoming a reality. The possibility of being able to minimize adjacent segment degeneration is exciting; however, much more intermediate and long-term outcome-based data are going to be necessary to prove that this technology supersedes the current gold-standard of anterior fusion. Biomechanical studies demonstrate that disc replacement creates less adjacent level strain than fusion. Hopefully, with time, long-term studies will prove that this correlates to a lower incidence of adjacent level degeneration.

Recent clinical reports show promising early data suggesting that artificial disc replacement is comparable with fusion at least in the short-term. Wear studies suggest that there may be less potential for aseptic loosening than in large joint arthroplasty, although the reality of this will only be borne out with more follow-up

time. Although early reports of success in the United States with the TDR suggest that the intended effects are being achieved, the final results of arthroplasty with these devices and of cervical arthroplasty are pending the outcomes of long-term studies.

This study demonstrates the promising 24-month outcomes of cervical disc arthroplasty using the BRYAN Disc in comparison with the “gold-standard” (ACDF). Follow-up in this study is similar in duration to the published data of many other cervical arthroplasty devices under investigation in US trials.<sup>25-30</sup> Although intermediate and long-term data collection will ultimately determine the feasibility of this device, this investigation lends strong support to a new technique for patients with cervical radiculopathy and myelopathy.

### REFERENCES

1. Bohlman HH, Emery SE, Goodfellow DB, et al. Robinson anterior cervical discectomy and arthrodesis for cervical radiculopathy. Long-term follow-up of one hundred and twenty-two patients. *J Bone Joint Surg Am.* 1993;75:1298-1307.
2. Anderson PA, Sasso RC, Rouleau JP, et al. The Bryan Cervical Disc: wear properties and early clinical results. *Spine J Official J North Am Spine Soc.* 2004;4(6 suppl):303S-309S.
3. Goffin J, Casey A, Kehr P, et al. Preliminary clinical experience with the Bryan Cervical Disc Prosthesis [see comment]. *Neurosurgery.* 2002;51:840-845; Discussion 845-847.
4. Goffin J, Van Calenbergh F, van Loon J, et al. Intermediate follow-up after treatment of degenerative disc disease with the Bryan Cervical Disc Prosthesis: single-level and bi-level. *Spine.* 2003; 28:2673-2678.
5. Lafuente J, Casey AT, Petzold A, et al. The Bryan Cervical Disc Prosthesis as an alternative to arthrodesis in the treatment of cervical spondylosis. *Journal of Bone & Joint Surgery-British Volume.* 2005;87:508-512.
6. Anderson PA, Rouleau JP, Bryan VE, et al. Wear analysis of the Bryan Cervical Disc Prosthesis. *Spine.* 2003;28:S186-S194.
7. Sasso RC, Rouleau JP. Cervical Kinematics in ACDF and Disc-Replaced Subjects. 2004. NASS 20th Annual Meeting-Submitted Abstract, unpublished work.
8. Hilibrand AS, Carlson GD, Palumbo MA, et al. Radiculopathy and myelopathy at segments adjacent to the site of a previous anterior cervical arthrodesis. *J Bone Joint Surg Am Volume.* 1999;81:519-528.
9. Goffin J, van LJ, Van CF, et al. Long-term results after anterior cervical fusion and osteosynthetic stabilization for fractures and/or dislocations of the cervical spine. *J Spinal Disord.* 1995;8:500-508; Discussion 499.

10. Goffin J, Geusens E, Vantomme N, et al. Long-term follow-up after interbody fusion of the cervical spine. *J Spinal Disord Tech*. 2004;17:79–85.
11. Eck JC, Humphreys SC, Lim TH, et al. Biomechanical study on the effect of cervical spine fusion on adjacent-level intradiscal pressure and segmental motion. *Spine*. 2002;27:2431–2434.
12. Fuller DA, Kirkpatrick JS, Emery SE, et al. A kinematic study of the cervical spine before and after segmental arthrodesis. *Spine*. 1998;23:1649–1656.
13. Brodke DS, Zdeblick TA. Modified Smith-Robinson procedure for anterior cervical discectomy and fusion. *Spine*. 1992;17(10 suppl): S427–S430.
14. Sandhu HS, Grewal HS, Parvataneni H. Bone grafting for spinal fusion. *Orthop Clin North Am*. 1999;30:685–698.
15. Brown CA, Eismont FJ. Complications in spinal fusion. *Orthop Clin North Am*. 1998;29:679–699.
16. Summers BN, Eisenstein SM. Donor site pain from the ilium. A complication of lumbar spine fusion. *J Bone Joint Surg Br*. 1989;71:677–680.
17. Silber JS, Anderson DG, Daffner SD, et al. Donor site morbidity after anterior iliac crest bone harvest for single-level anterior cervical discectomy and fusion. *Spine*. 2003;28:134–139.
18. St John TA, Vaccaro AR, Sah AP, et al. Physical and monetary costs associated with autogenous bone graft harvesting. *Am J Orthop (Chatham, NJ)*. 2003;32:18–23.
19. Medtronic Sofamor Danek. Bryan Cervical Disc System-Single Level Surgical Technique [pamphlet]. Medtronic Sofamor Danek USA, Inc, 2004.
20. Sekhon LH. Cervical arthroplasty in the management of spondylotic myelopathy. *J Spinal Disord Tech*. 2003;16:307–313.
21. Duggal N, Pickett GE, Mitsis DK, et al. Early clinical and biomechanical results following cervical arthroplasty. *Neurosurg Focus*. 2004;17:E9.
22. Anderson PA, Sasso RC, Metcalf NH, et al. Reoperation Rates for Cervical Arthroplasty vs Arthrodesis. 2004. NASS 20th Annual Meeting-Submitted Abstract, unpublished work.
23. Leung C, Casey AT, Goffin J, et al. Clinical significance of heterotopic ossification in cervical disc replacement: a prospective multicenter clinical trial. *Neurosurgery*. 2005;57:759–763.
24. Pickett GE, Sekhon LH, Sears WR, et al. Complications with cervical arthroplasty. *J Neurosurg Spine*. 2006;4:98–105.
25. Bertagnoli R, Duggal N, Pickett GE, et al. Cervical total disc replacement, part two: clinical results. *Orthop Clin North Am*. 2005; 36:355–362.
26. Wigfield CC, Gill SS, Nelson RJ, et al. The new Frenchay artificial cervical joint: results from a two-year pilot study. *Spine*. 2002; 27:2446–2452.
27. Wigfield C, Gill S, Nelson R, et al. Influence of an artificial cervical joint compared with fusion on adjacent-level motion in the treatment of degenerative cervical disc disease. *J Neurosurg*. 2002;96(1 suppl):17–21.
28. Porchet F, Metcalf NH. Clinical outcomes with the Prestige II cervical disc: preliminary results from a prospective randomized clinical trial. *Neurosurg Focus*. 2004;17:E6.
29. Pimenta L, Leon M, McAfee PC, et al. Single Versus Multilevel Cervical Disc Replacements. Two Year Follow up of the PCM Discs [abstract]. 2005 AANS Annual Meeting. 4-19-2005.
30. Pimenta L, Diaz R, McAfee PC, Crockard A, Cappuccino A, Cunningham B. Porous Coated Motion (PCM) Cervical Arthroplasty: Biomechanics, Design Considerations, Clinical Outcomes. 10-9-2005, unpublished work.
31. Medtronic Sofamor Danek. Bryan Cervical Disc Image (Slide). Medtronic Sofamor Danek USA, Inc; 2004.
32. Sasso RC, Hacker R, Heller JG. Artificial disc versus fusion for the treatment of cervical radiculopathy: a prospective, randomized study. 2005, unpublished work.